

DAE Pumps Tampa 4110

Submersible
Slurry and Sand Pump



DAEPUMPS.COM

info@daepumps.com

(760) 821-8112



Opened Impeller

Strainer Impeller

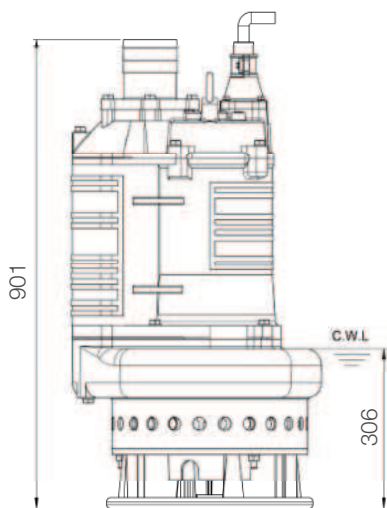
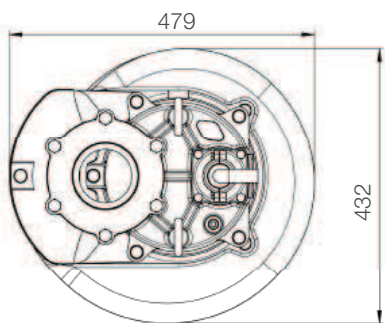

unit : mm

Weight : 191kg / 421 lbs

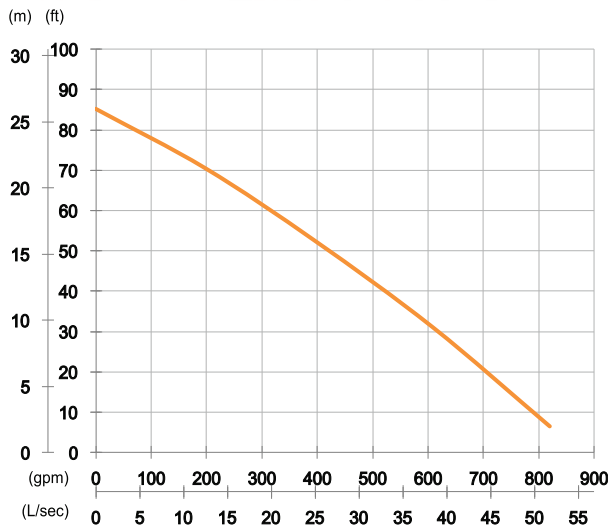

Shaft Speed : 1750 rpm

Outlet : 100mm, 4in

OUTPUT	HEAD	FLOW
11 kW	Rated : 16m, 52ft	Rated : 25 L/s, 396 gpm
15 HP	Max : 26m, 85ft	Max : 51.7 L/s, 819 gpm

Solid Passage : 25mm, 1in

Pump Type		Electric Submersible Pumps
		3-Phase
Motor	Type	Induction Motor
	Poles	4 Pole
	Insulation	Class F
	Protector	Circle Thermal Protector
	Starter	D.O.L.
Lubricant		Food Grade (ISO VG32)
Impeller Type		Opened or Strainer Options
Shaft Seal		Double Mechanical Seal
		Silicon Carbide VS Ceramic / Carbon
Bearings		C3 Shielded ball bearings
Cable		PVC (CSA Certified) / H07BQ-F
		10m (33ft) or longer upon request.
Materials	Pump Casing	Ductile Iron
	Impeller	Chromium Iron
	Motor Frame	Gray Iron
	Motor Shaft	Stainless Steel
	Wear Plate	Chromium Iron
	Agitator	Chromium Iron
Max. Liquid Temperature		40°C (104°F)
Max. Submersion Depth		20m (66ft)
pH Range		pH 5 - pH 8